

**Baureihe GZ 181 Gleichgangzylinder mit Mittelzapfenlager
180 bar – Reihe**

Baureihe	Kolben Ø	Stange Ø	R Ø	Maße in mm								Le8 Ø	Temperatur °C –30 / +110		
				A	B	C	D	F	G	J	K		O	P Druckkraft / Zugkraft daN / 180 bar	
GZ 181															
G-40-20-HUB	40	20	50	135	30	50	16	43	G3/8	60	75	115	30	M16x1.5	1696
G-40-28-HUB	40	28	50	135	30	50	16	43	G3/8	60	75	115	30	M16x1.5	1153
G-50-28-HUB	50	28	60	135	40	50	22	43	G3/8	70	85	125	30	M22x1.5	2426
G-50-35-HUB	50	35	60	135	40	50	22	43	G3/8	70	85	125	30	M22x1.5	1801

Bestellung: Baureihe GZ 181 Kolben Ø40 Stange Ø28 Hub 100

Hublänge frei wählbar

Artikel-Nr. **GZ 181 / G – 40 – 28 – 100 - 235**

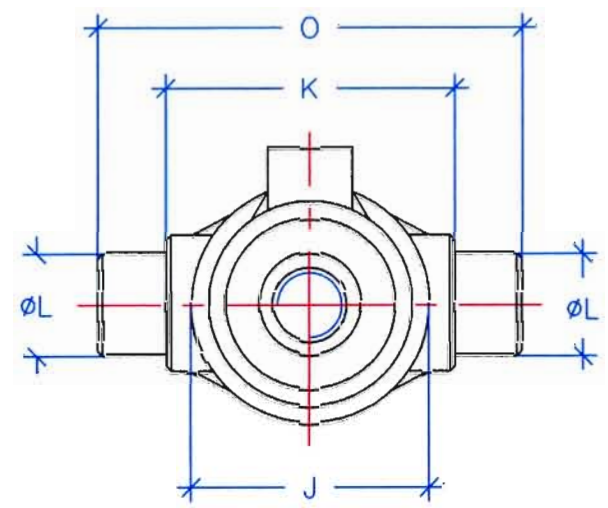
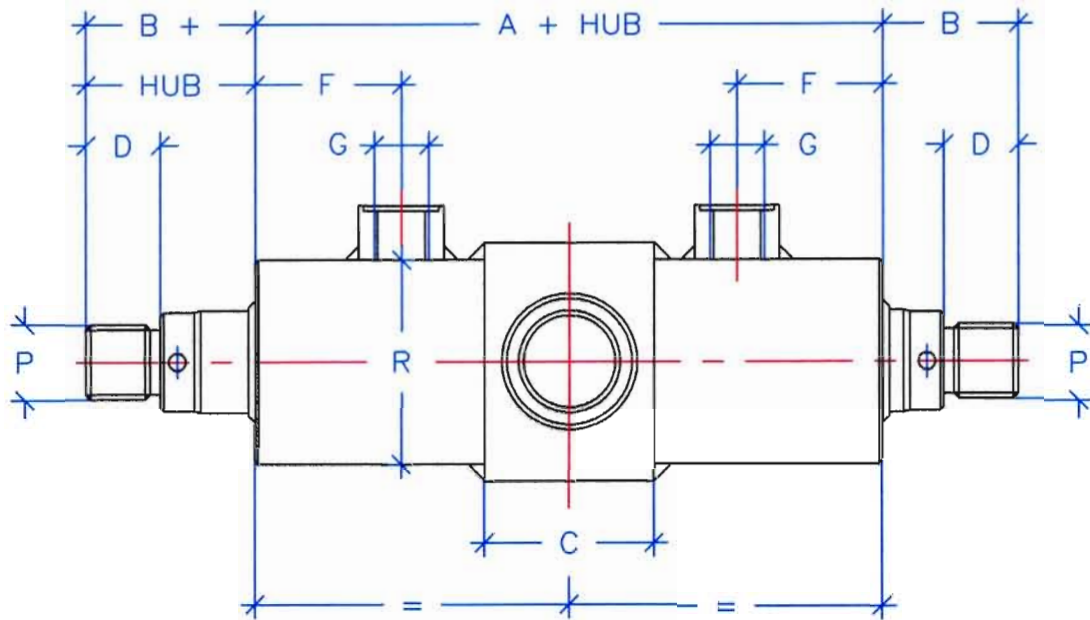

**Baureihe GZ 181 Gleichgangzylinder mit Mittelzapfenlager
180 bar – Reihe**

Baureihe	Kolben Ø	Stange Ø	R Ø	Maße in mm										Le8 Ø	Temperatur °C -30 / +110	
				A	B	C	D	F	G	J	K	O	P		Druckkraft / Zugkraft daN / 180 bar	
GZ 181																
G-63-36-HUB	63	36	75	135	50	55	28	43	G1/2	90	110	150	35	M28x1.5	3788	
G-63-42-HUB	63	42	75	135	50	55	28	43	G1/2	90	110	150	35	M28x1.5	3117	
G-80-42-HUB	80	42	95	140	55	60	35	43	G1/2	110	130	180	40	M35x1.5	6553	
G-80-55-HUB	80	55	95	140	55	60	35	43	G1/2	110	130	180	40	M35x1.5	4771	

Bestellung: Baureihe GZ 181 Kolben Ø40 Stange Ø28 Hub 100
 Hublänge frei wählbar
 Artikel-Nr. **GZ 181 / G – 63 – 42 – 100 - 235**